

### Inside Mount

Fig 1.

#### Front View

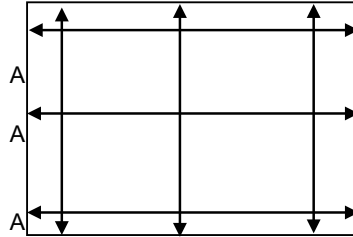

A - Measure Top, Middle And Bottom Of Reveal  
 B - Measure Left, Middle And Right Of Reveal

#### Side View

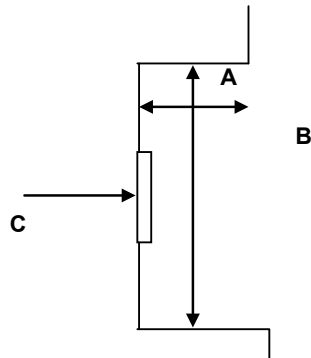

A - Height Of Window Opening  
 B - Width Of Window Reveal  
 C - Depth Of Handle Or Burglar Bar

#### Side View

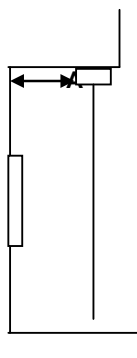

A - Position Of Blind - From Window

Contact Details: Tel: 031 579 2670  
 Fax: 031 579 2680  
 Email: [orders@ventolite.co.za](mailto:orders@ventolite.co.za)  
 Web: [www.ventolite.co.za](http://www.ventolite.co.za)

Address: Ventolite Blinds CC  
 Unit 19 Springriver Park  
 48 Ebonyfield Avenue  
 Springfield Park  
 Durban